

Sewing Machine Badge: Janome My Style 100

Age: Grade 9-Adult

LEVEL 1

Objectives:

- To learn the basic functions of the sewing machine and to be able to thread and sew a running stitch with supervision.

1. Identify parts of machine and their functions

1. **Bobbin Winder Stopper** - Stops bobbin from winding when full.
2. **Bobbin Winder Spindle** - Holds bobbin when filling it.
3. **Spool Pin** - Holds spool of thread for sewing and winding bobbin.
4. **Bobbin Winder Thread Guide** - Guides thread from spool of thread to bobbin to prevent tangling when filling bobbin.
5. **Thread Guide** - Guide for thread when threading machine for sewing (1st step).
6. **Thread Take-up Lever** - Guide for thread after feeding it in thread channel guide (2nd/3rd steps).
7. **Face Plate** - Outside plate of machine.
8. **Thread Cutter** - Used for cutting threads during sewing.
9. **Needle Plate** - Plate for guiding, sewing, and covering bobbin with hole for needle.
10. **Extension Table** - Removable extension table which holds extra accessories.
11. **Hook Cover Plate** - Covers bobbin well.
12. **Hook Cover Plate Release Button** - Opens hook cover plate to place and replace bobbin.
13. **Thread Tension Dial** - Changes amount of thread tension; dependent on fabric thickness and needle size.
14. **Reverse Stitch Button** - Pushes in to allow machine to sew in reverse.
15. **Stitch Length Dial** - Determines length of stitch.

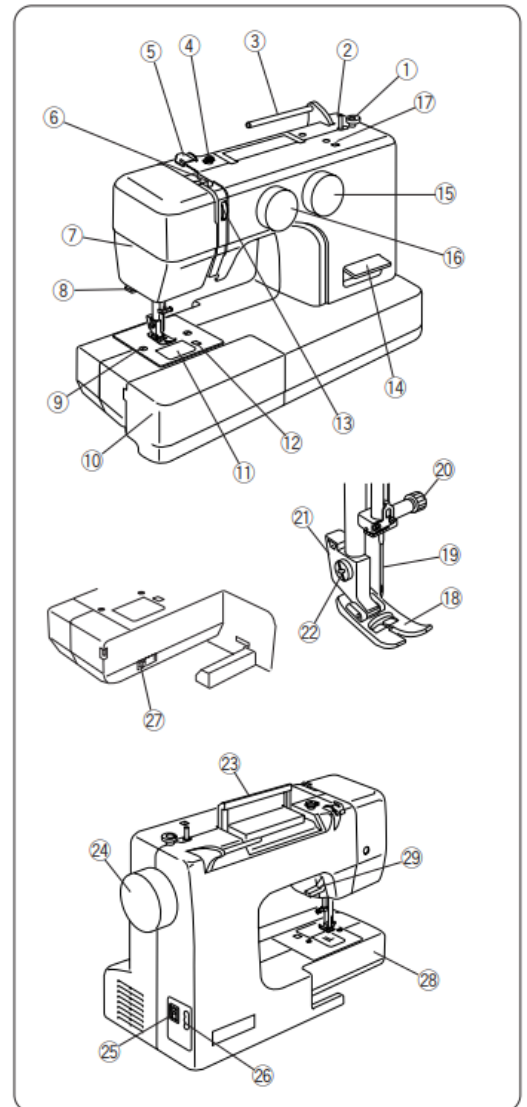

Sewing Machine Badge: Janome My Style 100

Age: Grade 9-Adult

16. **Pattern Selector Dial** - Determines kind of stitch (straight, zigzag, overcast, etc.).
17. **Square Hole for Additional Spool Pin** - For adding extra spool pin for two spool sewing.
18. **Presser Foot** - Presses down fabric onto feed dogs while sewing.
19. **Needle** - Machine needle, size dependent on fabric type.
20. **Needle Clamp Screw** - Tightens or loosens needle for replacement.
21. **Presser Foot Holder** - Holds presser foot in place; loosen to change kind of foot.
22. **Setscrew** - Loosen to replace presser foot holder.
23. **Carrying handle**
24. **Handwheel** - Used to turn needle by hand.
25. **Power Switch** - Turns machine off and on.
26. **Cord Socket** - Socket to plug power/presser foot cord into machine.
27. **Drop Feed Lever** - Drops feed dogs down for specialty stitching.
28. **Free-Arm** - Remove extension table for sewing sleeves, items with small openings; darning.
29. **Presser Foot Lifter** - Raises and lowers presser foot and tightens/loosens thread tension.
30. **Power Cord and Foot Pedal (not shown in photo)** - Cord connects machine to power outlet and foot pedal is used to run the machine.

Standard Accessories:

1. **Zipper Foot E** - Presser foot used to sew on zippers.
2. **Blind Hemming Foot G** - Presser foot used for blind hemming.
3. **Sliding Buttonhole Foot J** - Presser foot for four step buttonholes.
4. **Needles** - Various sizes.
5. **Bobbins** - For bottom thread.
6. **Screwdriver** - For unscrewing needle clamp screw and setscrew.
7. **Lint Brush** - For cleaning machine.

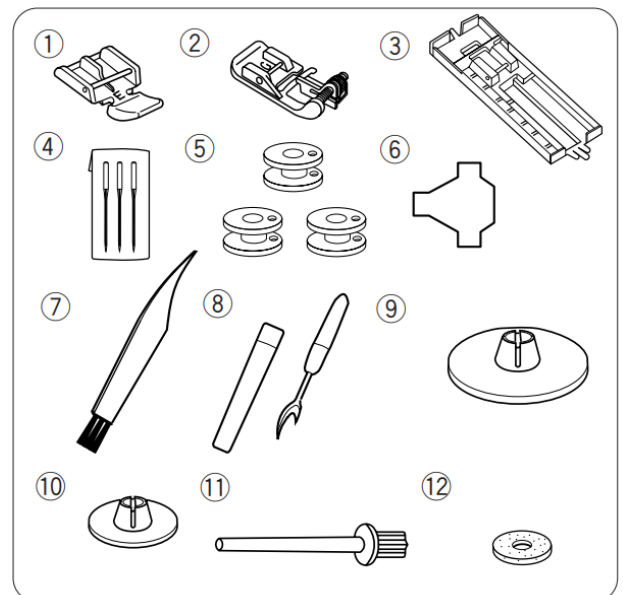

Sewing Machine Badge: Janome My Style 100

Age: Grade 9-Adult

8. **Seam Ripper/Buttonhole Opener** - For undoing mistakes and finishing buttonholes.
9. **Spool Holder (large)** - For holding large spools of thread on spool pin.
10. **Spool Holder (small)** - For holding small spools of thread on spool pin.
11. **Additional Spool Pin** - To replace spool pin or for two thread sewing.
12. **Felt Cushion** - Keeps spool of thread from grinding.

2. Safety Guidelines

- Machine use is for customers Grade 9-Adult.
- Use only the attachments, power cord, and accessories that come with machine.
- Never operate machine if the power cord is frayed or damaged in any way.
- Do not drop the machine.
- To disconnect the machine, turn the controls to off (“O”), and remove plug from outlet (do not pull by the cord).
- Keep your fingers away from all moving parts.
- Use proper needle plate; do not use bent needles.
- Always turn machine off when adjusting needle or presser foot, threading the bobbin or needle.

3. Setting up the machine -- power cord, presser foot, and needle

- **Power Cord** - Turn power switch to off position (“O”). Insert plug into machine socket and then plug power supply into the wall socket. Turn machine on. Place foot pedal on floor beneath machine.
- **Foot Pedal** - Works like a gas pedal in a car. Press down to go faster; lift up to slow down or stop.
- **The Presser Foot** - To raise or lower, use lifter on the inside of the machine arm. Lift to place fabric or remove fabric. Always remember to lower presser foot before pressing the foot pedal. If your fabric is especially heavy, you can lift the presser foot lifter slightly higher in order to make room under the presser foot. Choose the correct presser foot for the stitch you are planning to sew.

Sewing Machine Badge: Janome My Style 100

Age: Grade 9-Adult

To change the presser foot:

1. Raise the needle to the highest position by turning the handwheel counterclockwise.
2. Raise the presser foot and press the lever on its back.
3. Remove presser foot.
4. Place desired presser foot so that the pin on the foot lies just under the groove on the foot holder. Lower foot lifter to lock the foot in place.

- **The Needle** - Choose the needle based on the type of fabric you are using (see Sewing Machine Needle Charts in Appendix I in the manual).

To change the needle:

1. Raise the needle by turning the handwheel and lower presser foot.
2. Loosen the needle clamp screw with screwdriver (included) by turning Counterclockwise.
3. Insert new needle into clamp with flat side of the needle facing the back of the machine. Push needle up until it stops and then re-tighten needle clamp screw.
 - To check needle to see if it's bent, place flat side of needle onto flat surface and check that the gap between needle and surface is consistent along the whole length of the needle. If needle is bent, discard and put new needle in machine.
 - Never use a blunt needle. Change needle after about eight hours of sewing.

4. Bobbin preparation

1. Setting the spool

- Place spool of thread on spool pin with thread winding underneath and toward the front of the machine (see illustration on page 16 in manual).
- Add spool holder to keep thread in place.

2. Winding the bobbin

- Hold thread and pass it under the thread guide.
- Guide the thread around the bobbin and pass thread through hole in bobbin from the inside to the outside. Put the bobbin on bobbin winder spindle.
- Push bobbin winder spindle to the right.
- Hold the free end of the thread in your hand and start the machine. Stop the machine when a few layers of thread have wound around your bobbin and cut loose thread close to the bobbin.
- Start the machine again and wind bobbin until machine stops automatically. Push bobbin winder spindle to the left, cut the thread, and remove bobbin from spindle.

Sewing Machine Badge: Janome My Style 100

Age: Grade 9-Adult

3. Inserting bobbin in machine (see illustration on page 20 in manual)

- Place the bobbin in bobbin holder with the thread counterclockwise and loose thread facing you.
- Guide the thread into the front notch on the front side of holder. Draw the thread to the left and slide it between the tension spring blades.
- Continue to draw thread lightly until the thread slips into the side notch.
- Pull about 4 inches of thread out. Attach the hook cover plate.

4. Removing bobbin from machine

- Push hook cover plate release button to the right and remove cover plate.
- Lift out the bobbin.

5. Threading the machine (see illustration on page 22 in manual)

- Raise the presser foot and raise the needle to the highest position.
- Draw the thread from the spool on top of the machine and pass it under thread guide (#1).
- Draw the thread down along the right channel, pull it up around the bottom of the thread guide plate, and up along the left channel (#2).
- Firmly draw thread from right to left over the thread take-up lever and down into the take-up eye (#3).
- Take thread down the left channel again and slip behind the needle bar thread guide from the left (#4).
- Pass thread through the eye of the needle from front to back (be careful not to tangle it as you thread it through).

6. Threading the bobbin and drawing thread up from the bottom

(see illustration on page 24 in manual)

- Raise the presser foot and hold the needle thread lightly with your left hand
- Turn the handwheel slowly toward you one complete turn. Bring the bobbin thread up by gently tugging on the needle thread as you turn the wheel.
- Pull thread up gently until it is free from the machine. Untangle threads and pull 4 inches of thread back behind the presser foot.

Sewing Machine Badge: Janome My Style 100

Age: Grade 9-Adult

7. Setting thread tension, stitch pattern, and stitch length

(see illustrations on pages 26, 28)

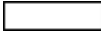
- Select the stitch pattern by raising needle to highest position and turning the pattern selector dial to the symbol of your desired stitch pattern¹
- Turn the stitch length dial to set your desired stitch length (the higher the number, the longer the stitch). The  symbol is for buttonholes.
- Set the thread tension, using the tension dial, to the correct tension depending on the type of fabric, number of layers, and sewing method used.

8. Sew a running stitch on a piece of fabric.

Stitch pattern: A

Stitch length: 1.5 - 4

Thread tension: 2 - 6

Presser foot: Zigzag foot A

- Raise the presser foot and place the fabric under the foot.
- Lower the needle into the fabric.
- Lower the presser foot and smooth the threads toward the back. Press down on the foot control slowly and gently guide the fabric into the machine. The machine will pull the fabric through for you. You need only to guide it so that the seam is straight and the correct width.
- To finish your seam, press the reverse stitch lever and sew several stitches in reverse at the end of the seam (this secures the stitches so that they do not unravel)
- Raise the presser foot and remove the fabric, gently pulling the threads toward the back of the machine.
- Snip the threads off close to the seam, leaving about 4 inches of threads behind the presser foot.

9. Using the seam guide

- The seam guides on the needle plate help you to measure the correct seam allowance. Always check your pattern for the seam allowance you should set when you sew.

¹ See Appendix II in the manual for Stitch patterns

Sewing Machine Badge: Janome My Style 100

Age: Grade 9-Adult

10. Cleaning the machine

- Clean the feed dogs (see illustration on pages 64, 66).
- Unplug the machine and remove the presser foot and needle.
- Remove the screw on the needle plate, remove the needle plate, and take out the bobbin.
- Lift up the bobbin holder and remove it.
- Brush out dirt and lint with small brush. Wipe bobbin holder with soft, dry cloth.
- Clean the feed dogs and hook area with small brush.
- Wipe hook race with soft, dry cloth.
- Insert bobbin holder into machine and make sure the knob of the holder fits next to the stopper on the hook race.
- Replace the bobbin, attach the needle plate, and replace the screw.

11. Properly disconnect and store the machine after use.

Sewing Machine Badge: Janome My Style 100

Age: Grade 9-Adult

LEVEL 2

Objectives:

- *Learn troubleshooting tips and independently demonstrate Level 1 procedures to earn the sewing machine badge.*
-

1. Wind bobbin and thread machine with no help

2. Sew a running stitch on a piece of fabric with no help

3. Seam guides on needle plate

- Numbers indicate the distance between the center needle position and the seam guide.
- Standard seam allowance is $\frac{5}{8}$ inch.
- Always check your pattern for the correct seam allowance.
- Beginners: put a piece of masking or blue tape along the seam measurement number you require to help you sew the correct distance.

4. Turning a square corner

- When the fabric edge facing you lines up with the cornering guide (see illustration on page 34 in manual), stop stitching and lower the needle into the fabric by turning the handwheel toward you.
- Raise the presser foot and pivot the fabric so the edge of the fabric will align with the $\frac{5}{8}$ inch seam guide.
- Lower the presser foot and start stitching in the new direction.

Sewing Machine Badge: Janome My Style 100

Age: Grade 9-Adult

5. Reverse stitch to finish seam

- Press the reverse stitch lever and sew several stitches in reverse at the end of the seam.
- Raise the presser foot and remove the fabric, drawing threads to back.
- Cut threads close to fabric.

6. Sewing a circle

- It is always best to mark your circle on your fabric, especially if you are a beginner.
- Make sure you know the appropriate seam allowance marking on your needle plate. For curves, you want to keep your eye on the seam at the exact measurement **in line** with needle, not before the needle.
- If your seam will be hidden, it helps to shorten your stitch length. Smaller stitches make a smoother curve.
- Stitch very slowly. You may even want to walk the needle along using your handwheel.
- If the fabric bunches around the needle as you turn it, lift the presser foot to release the fabric and then put the foot back down to continue. Make sure that the needle is in the down position, securing the fabric, before lifting the presser foot.
- Trim close to the edge and then snip small wedges from the fabric within the seam allowance.
- Turn the fabric right side out and press carefully.

7. Zigzag stitch

Stitch pattern: C

Stitch length: 0.5 - 3

Thread tension: 2 - 5

Presser foot: Zigzag foot A

Use for overcasting, sewing on buttons, and finishing.

Sewing Machine Badge: Janome My Style 100

Age: Grade 9-Adult

8. Sew with pins

- When you have pins as a replacement for a basting stitch, you need to be careful when sewing.
- Always pin so that the head of the pin is at a 90 degree angle from your seam line.
- Sew your seam slowly, always pulling the next pin out before it reaches your presser foot.
- Never sew over a pin; if the needle hits the pin, you can damage or even break your needle.

9. Troubleshooting

Needle thread or bobbin thread breaks

- Is it threaded properly?
- Is the tension set too tight?
- Is the needle bent or blunt?
- Is the needle inserted incorrectly?
- Is the thread pulled to the rear of the needle?
- Is the thread too heavy or too fine for the needle?
- Has lint collected in the bobbin holder?
- Is the bobbin damaged?

Needle breaks

- Is it inserted correctly and is the clamp screw tightened?
- Is it blunt or bent?
- Is the foot the correct one for the stitch being sewn?
- Is the needle too fine for the fabric?

Needle thread loops

- Is the needle thread tension too loose?
- Is the needle size correct for the thread?

Sewing Machine Badge: Janome My Style 100

Age: Grade 9-Adult

Skipped stitches

- Is the needle correctly inserted?
- Is the needle bent or blunt?
- Are the needle and/or thread the correct weight for the fabric used?
- Is the machine threaded correctly?
- Is the needle a good quality needle?

Seam puckering

- Check the needle tension
- Is the machine threaded correctly?
- Is the needle too heavy for the fabric?
- Is the stitch length too long for the fabric?
- Does your fabric need a stabilizer?

Cloth not feeding smoothly

- Is the feed dog full of lint?
- Are the stitches too fine?
- Was the feed dog not raised?

Machine does not work

- Is it plugged in?
- Is the thread caught in the hook race?
- Is the handwheel set for bobbin winding?

Noisy operation

- Is the feed dog full of lint?
- Has lint collected in the bobbin holder?